

Portoni in Legno

Wooden doors
Holztore



Wood Line / Pegaso Line

Per Breda sono i dettagli a fare la differenza

For Breda are the details that make the difference
Für Breda sind die Details die den Unterschied machen



Qualità
Ogni portone Breda nasce per essere unico. La progettazione viene effettuata con sistemi informatici che eliminano ogni imprevisto realizzativo. Il risultato è il migliore esempio di qualità totale che dura per sempre.

Quality
Each Breda door is designed to be unique. The design is made through data processing which avoids any kind of unexpected event during production. The result is the best total quality that will last forever.

Qualität
Jedes Breda Sektionaltor ist ein Einzelstück. Die Entwicklung wird, durch Präzisionsinstrumente durchgeführt, um eventuelle Produktionsfehler zu vermeiden. Das Ergebnis ist das beste Qualitätsbeispiel, das eine lange Lebensdauer gewährt.

Sicurezza
Ogni portone sezionale Breda prevede una serie di sistemi di sicurezza come dotazione standard. Non a caso ogni realizzazione è il risultato di un processo produttivo altamente qualificato: a partire dalla progettazione, effettuata con strumenti informatici all'avanguardia, fino ai test di verifica effettuati su ciascun pezzo al fine di controllare, analizzare e accertare qualità e sicurezza.

Safety devices
Each Breda sectional door includes a range of security systems as standard equipment. In fact every Breda product is the result of a highly skilled production process: starting from the design, made with advanced tools, up to the verification tests performed on each component in order to monitor, analyze and verify its quality and safety.

Sicherheitsvorrichtungen
Jedes Breda Tor erfüllt alle Sicherheits-Normen, dank Vorrichtungen, die, serienmäßig geliefert werden. Jedes Teil kommt aus hochqualifizierten Produktionsverfahren: von der Planung, die durch Präzisionsinstrumente durchgeführt wird, bis zur Qualitäts- u. Sicherheits-Kontrolle, auf jedem einzelnen Stück.

Comfort
Un portone sezionale Breda si apre e si chiude con grande facilità. Tanti gli elementi che rendono immediato e confortevole l'utilizzo del portone: dalla possibilità di installare un piccolo motore "silenzioso" sul soffitto, al movimento controllato e reso sicuro dalla presenza di fotocelle, dal telecomando semplice e pratico alla luce di cortesia automatica.

Comfort
You can easily open and close a Breda sectional door. Several features make its use fast and comfortable: the option of a small and "silent" motor fixed on the ceiling, the presence of photocells that assure a controlled and safe motion, the easy to use remote control and automatic courtesy light.

Comfort
Ein Breda Sektionaltor lässt sich ganz leicht öffnen und schließen. Verschiedene Elemente ermöglichen eine einfache Bedienung. Dazu gehören: ein leiser Deckenantrieb, Lichtschranken, ein kleiner und praktischer Handsender, automatische Innenbeleuchtung.

Basculante Swing

"Up & Over" door / Kipptor



Un portone basculante Breda non necessita della guida a soffitto.

A Breda up and over door does not need tracks on the ceiling.
Ein Breda Schwingtor braucht nicht Schienen an der Decke.



Un portone basculante Breda garantisce un elevato isolamento termico.

A Breda up and over door provides a high thermal insulation.
Ein Breda Schwingtor bietet eine hohe Wärmedämmung.

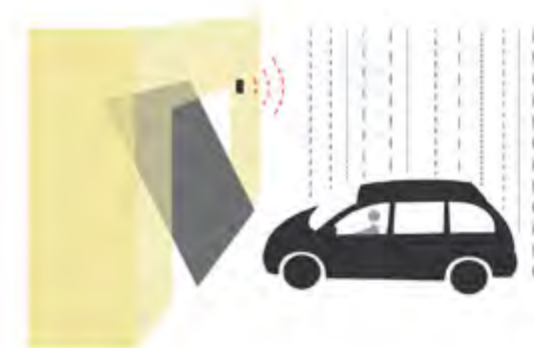

Un portone basculante Breda è molto agevole da aprire, scegliendo una versione motorizzata!

A Breda up and over door is very easy to open, choosing a motorized version!
Ein Breda Schwingtor ist sehr leicht zu öffnen, in der motorisierte Version!

Sezionale

Sectional door / Sektionaltor



Un portone sezionale Breda permette di utilizzare appieno lo spazio interno ed esterno del garage.

A Breda sectional door allows the use of whole internal and external space of the garage.
Ein Breda Sektionaltor ermöglicht die volle Nutzung des Raumes innerhalb und außerhalb der Garage.



Un portone sezionale Breda garantisce un elevato isolamento termico.

A Breda sectional door provides a high thermal insulation.
Ein Breda Sektionaltor bietet eine hohe Wärmedämmung.



Un portone sezionale Breda è molto agevole da aprire, scegliendo una versione motorizzata!

A Breda sectional door is very easy to open, choosing a motorized version!
Ein Breda Sektionaltor ist sehr leicht zu öffnen, in der motorisierte Version!



Breda Sistemi Industriali racchiude valori e requisiti importanti di qualità, sicurezza e cura estetica del prodotto.

Breda Sistemi Industriali meets important requirements for quality, safety and cares about product appearance.

Breda Sistemi Industriali legt großen Wert auf Qualität, Sicherheit und wohlfühlichem Design.

L'azienda è costantemente impegnata nello studio e nella ricerca di nuovi sistemi, materiali e tecnologie in grado di dare risposte alle esigenze estetiche, architettoniche e di praticità del vivere moderno. La capillarità sul territorio della rete vendita garantisce inoltre un servizio sempre veloce e competente, direttamente a domicilio. Scegliere Breda Sistemi Industriali significa scegliere sempre il meglio: tutti i prodotti sono sottoposti a specifici test di verifica per controllare e garantire qualità e sicurezza.

Company Breda is constantly engaged in studies and research of new materials and technologies to meet the aesthetic, architectural and practicality needs of modern living. The presence in the territory of our sales network grants a fast and competent service, directly at home. To choose Breda Sistemi Industriali means selecting always the best: all products are subject to specific tests to monitor and ensure quality and safety.

Seit immer ist die Firma Breda auf der Suche neuer Systeme, Materialien und Technologien, um die Bedürfnisse der heutigen Wohntendenz und architektonische Eigenschaften, zufrieden zu stellen. Unser Vertriebsnetz garantiert immer ein schnellen und kompetenten Service, frei Haus. Breda Sistemi Industriali bedeutet das Beste: zertifizierte und geprüfte Produkte, die Qualität und Sicherheit garantieren.



Oblò e Pannelli
Inspection windows and Panels
Bullaugen und Paneele

Automazioni, telecomandi e Maniglie
Motors, Remote controls and Handles
Antriebe, Handsender und Griffe



Liscio
Smooth
Glatt



Civic



Gara



Polls



Top

Sicurezze e plus
Plus and safety devices
Plus und Sicherheiten



Cerniere verniciate non scalabili, in alluminio
Aluminium lacquered hinges, unclimbable
Lackierte und unersteigbare Scharniere, aus Aluminium (Wood Line)



Cerniere verniciate non scalabili, in alluminio
Aluminium lacquered hinges, unclimbable
Lackierte und unersteigbare Scharniere, aus Aluminium (Pegaso Line)



Mensole verniciate non scalabili, in alluminio
Aluminium lacquered brackets, unclimbable
Lackierte und unersteigbare Konsole, aus Aluminium (Wood Line)



Mensole verniciate non scalabili, in alluminio
Aluminium lacquered brackets, unclimbable
Lackierte und unersteigbare Konsole, aus Aluminium (Pegaso Line)



Fotocellule
Photocells
Lichtschranken



Motore a traino
Pulling drive motor
Deckenantrieb
Ultra Motion 800-1200



Motore a traino
Pulling drive motor
Deckenantrieb
SPY 550-650-800



Motore a traino
Pulling drive motor
Deckenantrieb
SLB 650



Motore a traino
Pulling drive motor
Deckenantrieb
SLB 650-800-1100



Motore laterale
Side direct drive
Seitlicher Antrieb
SOON



Lampeggiante a LED
LED flashing light
LED-Signalleuchte
12-24-220V



Telecomando per Ultra Motion
Remote control for Ultra Motion
Handsender für Ultra Motion



Telecomando
Remote control
Handsender
SPY - SOON



Telecomando per SL
Remote control for SL
Handsender für SL



Telecomando per SLB
Remote control for SLB
Handsender für SLB



Pulsantiera per Ultra Motion
Push-button panel for Ultra Motion
Schalttafel für Ultra Motion



Selettore numerico per Ultra Motion
Digital switch selector for Ultra Motion
Kodetaster für Ultra Motion



Sistema ad impronta digitale
Fingerprint identification system
Finger-print System



Laser segnalatore posizione di parcheggio per SLB
Park position laser for SLB
Park-Positionslaser für SLB



Segnalatore di prossimità per SLB
Presence detector for SLB
Bewegungsmelder für SLB



Lock a Buzzer antieffrazione
Burglar-proof magnetic lock and alarm buzzer
Magnet-Motorschloss und Alarmbuzzer-Warmbuzzer am SLB



Nera and Black
Schwarz

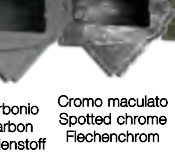

Carbonio
Carbon
Kohlenstoff



Cromo maculato
Spotted chrome
Flechenchrom



Bronzo
Bronze

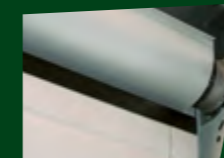

Carterizzazione delle molle
Spring casing
Federschutz



Carterizzazione delle guide
Tracks cover
Schutzabdeckung für Laufschiene



Guide verniciate
Painted tracks
Lackierte Laufschielen



Omega di rinforzo
Omega reinforcing profile
Omega Verstärkungsprofil



Paracadute molle
Spring break safety device
Federbruchsicherungsrichtung



Rotelle a forbice
Scissors rollers
Tandemlaufrolle (Wood Line)



Rotelle a forbice
Scissors rollers
Tandemlaufrolle (Pegaso Line)



Paracadute cavi (Wood Line)
Cable break safety device
Seilbruchsicherungsrichtung

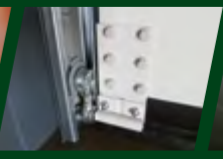

Paracadute cavi (Pegaso Line)
Cable break safety device
Seilbruchsicherungsrichtung



Trazione di sicurezza
Safety drive
Schlafseilsicherung



Molle zincate
Galvanized springs
Verzinkte Federn



Porta pedonale
Pedestrian door
Schlupftür

In ogni cosa che facciamo mettiamo la testa e il cuore

In everything we do we put head and heart
Alles was wir tun, ist herzlich und beruflich

LA STRUTTURA DEL TUO PORTONE IN LEGNO.
I portoni delle linee Wood Line e Pegaso Line, sono costituiti da pannelli in compensato marino di Okoumè, legno originario dell'Africa equatoriale. La sagoma anti pizzicamento brevettata, garantisce la sicurezza nel movimento del manto. La finitura del manto è garantita dall'applicazione di una mano di fondo di vernice impregnante e con due mani di finitura. I prodotti sono naturali e le vernici all'acqua, sull'onda della filosofia aziendale volta al rispetto dell'ambiente.

LA CURA DEL TUO PORTONE IN LEGNO.
La manutenzione è semplice e si limita alla pulizia periodica mediante prodotti neutri tipo sapone di marsiglia ed all'applicazione di prodotti protettivi commerciali atti al mantenimento del legno esposto alle intemperie.

YOUR WOOD DOOR'S STRUCTURE.
The doors from Wood Line and Pegaso Line ranges are made with marine plywood Okoumè, a wood native on the equatorial Africa. The patent anti-pinching profile grants the coat's safety movement. The finishing is granted with the application of double coat transparent protective filler. The products are natural and water painted, in accordance with the company philosophy of environment respect.

YOUR WOOD DOOR'S MAINTNANCE.
It's an easy maintenance, is requested a periodic cleaning with neutral products, as for example castile soap, and the application of protective products in order to save the wood exposed to weather conditions.

DER AUFBAU DEINES HOLZTORES.
Die Wood Line und Pegaso Line Tore, bestehen aus Furniersperrholz Okoumè, aus dem äquatorialen Afrika. Die Fingeklemmschutz-Paneele garantieren die Sicherheit während der Torblattsbewegung. Die Ausführung des Torblattes besteht aus einmal Imprägnierlack Anstrich und zweimal zusätzlichen Endlack. Gemäß der umweltfreundlichen Firmenphilosophie, werden ausschließlich natur Produkte und Wasserlacke angewendet.

DIE PFLEGE DEINES HOLZTORES.
Die Wartung ist ganz leicht und begründet sich einfach auf die regelmäßige Reinigung, durch neutrale Reinigungsmittel, wie Marseille-Seife und die zusätzliche Anbringung von kommerziellen Holz-Erhaltungsprodukten, wegen der Aussetzung im schlechten Wetter.

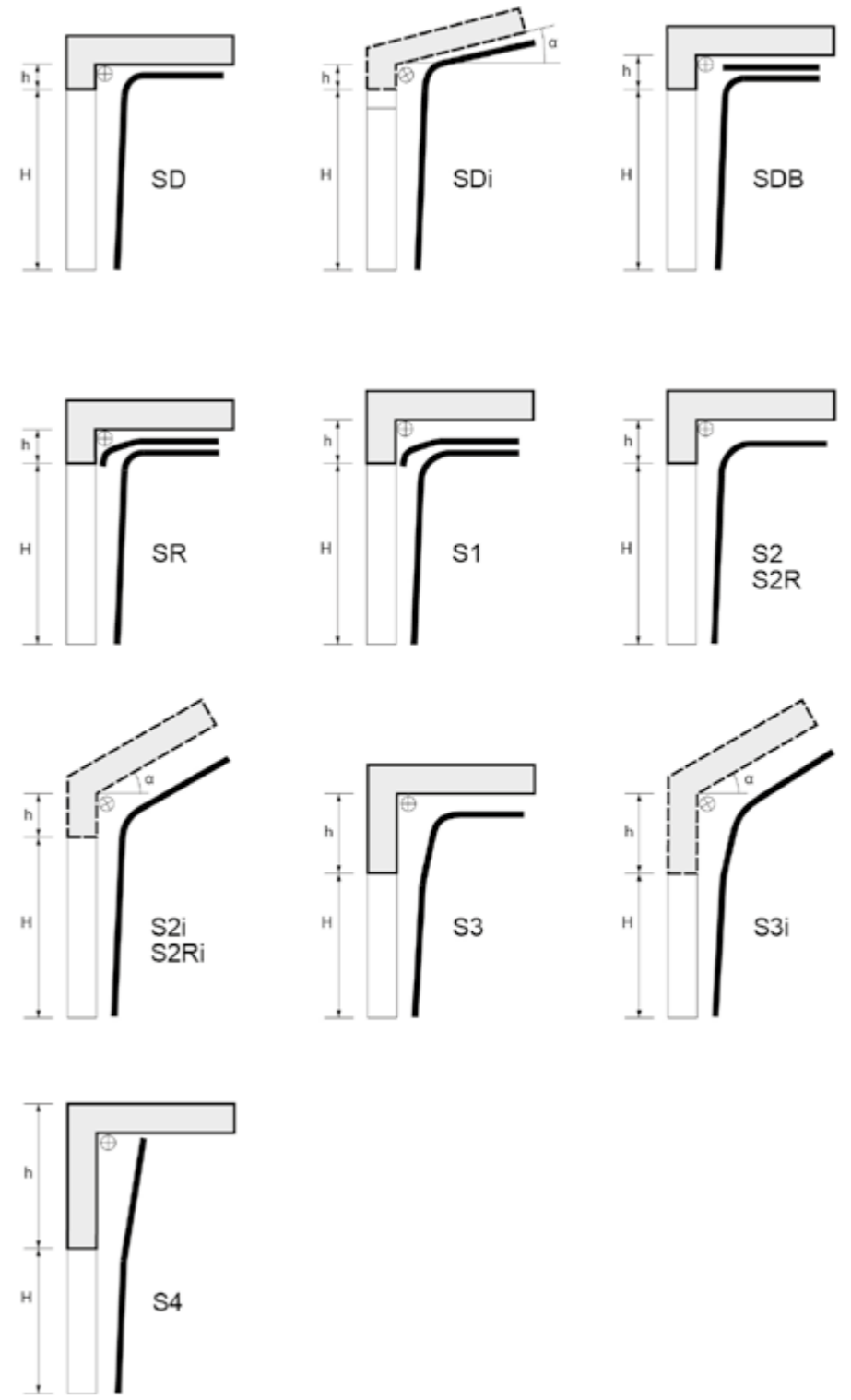



Cinque modelli declinabili secondo svariate esigenze di dimensioni, finiture e funzionalità che consentono di arredare e di conferire all'abitazione uno stile inconfondibile, caratterizzato dalla suggestione estetica di un materiale nobile come il legno.

Five models which fit according to several needs of dimensions, finishing and functionality, in order to furnish with a special aesthetic style, granted by a noble material, as wood is.

Fünf Modelle für jeden Geschmack. Verschiedene Masse, Farbe und Eigenschaften. Der unverkennbare, adlige Stil des Holzes einrichtet das Haus, mit dem höchsten ästhetischen Geschmack.

Wood Line

La collezione di sezionali in legno che unisce eccellenza, qualità della materia prima e innovazione tecnologica per un risultato unico ed esclusivo.

The collection of wooden sectional doors which match excellence, raw material's quality and technologic innovation, for a special and exclusive final result.

Diese Holztür-Linie enthält Vollkommenheit, Qualität und technologische Entwicklung, für ein perfektes und exklusives Ergebnis.





Top

CONFIGURAZIONI
/ Configurations / Ausstattungen

Il portone sezionale di punta della gamma è caratterizzato da pannelli di legno lavorati a specchio allineati o sfalsati. Top si distingue per la raffinatezza e la resistenza del legno Okoumè, che regala massimo stile ed eleganza al contesto abitativo in cui è inserito.

The main sectional door characterized by wooden panels with aligned or staggered blocks. Top distinguish itself by the refinement and the resistance of Okoumè wood, which grants a special style and elegance to the housing context.

Das Hauptmodell der Kollektion ist mit Holz-Kassettenpaneelen ausgestattet. Top ist ein gepflegtes und starkes Tor aus Okoumè Paneele, mit dem höchsten Stil und Eleganz.

COLORI e FINITURE LATO ESTERNO
External colours and finishes / Farben und Ausführungen der Außenseite

Pannelli in Okoumè
Okoumè panels / Paneele von Okoumè



Laccatura, verniciatura a campione
Lacquering, painting according to sample
Lackierung nach Muster



Cassettato
With blocks
Kassettenprägung

DISEGNO LATO ESTERNO
External side drawing / Motiv der Außenseite





Civic

CONFIGURAZIONI
/ Configurations / Ausstattungen

Il sezionale che unisce tradizione e futuro. In Civic il fascino retrò del legno si fonde mirabilmente con le moderne esigenze stilistiche e abitative grazie alla possibilità di inserimento di vetrate e porte nella struttura del portone, con un occhio di riguardo alla massima innovazione tecnologica, marchio di fabbrica dei sezionali Breda.

The sectional which mix tradition and future. With Civic, you have the retro appeal of wood melt with the modern stylistic and housing needs thanks to the possibility of glazing sections and inserted pedestrian doors, with special care to the technologic innovation, the trade mark of Breda's sectional doors.

Tradition und Zukunft. Der Zauber des Holzes mischt sich mit den modernsten Wohnbedürfnissen: eingebaute Schlupftüre und durchsichtige Alu-Sektionen entsprechen die ausgesuchteste Breda Technologie. Die Markenzeichen aller Breda Sektional-tore, deiner Verfügung.

disponibile con
available
verfügbar



Porta pedonale Stop&Go
Pedestrian door Stop&Go
Schlupftür Stop&Go

COLORI e FINITURE LATO ESTERNO

External colours and finishes / Farben und Ausführungen der Außenseite

Pannelli in Okoumè
Okoumè panels / Paneele von Okoumè



Neutro
Transparent
Durchsichtige

Noce chiaro
Light walnut
Heller Nussbaum

Noce scuro
Dark walnut
Dunkler Nussbaum

Douglas

Rovere chiaro
Light durmast
Heller Eichenholz

Rovere scuro
Dark durmast
Dunkler Eichenholz

Laccatura, verniciatura a campione
Lacquering, painting according to sample
Lackierung nach Muster

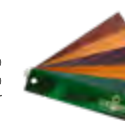

Fresature Orizzontali

Horizontal millings
Waagerechte Fräsungen

DISEGNO LATO ESTERNO

External side drawing / Motiv der Außenseite





Polis

CONFIGURAZIONI

/ Configurations / Ausstattungen

Nel portone sezionale Polis il calore, la qualità estetica e le magiche suggestioni africane del legno Okoumé vengono esaltate dalla particolare lavorazione dei pannelli con fresatura verticale. Il risultato è un concentrato di ricercatezza stilistica e massima resistenza nel tempo e agli agenti atmosferici.

On the sectional door Polis the warmth, the aesthetic quality and the magic African suggestions of Okoumé wood are enhanced by the particular processing on the panels, with the vertical millings. The result is a perfect mix of style and maximum time life, also against the atmospheric agents.

Besondere Senkrechte Fräsungen rühmen die ästhetischen Eigenschaften des zauberhaften, afrikanischen, Okoumé Holzes. Das Ergebnis ist eine Gesamtheit von Stil und langlebige wetterfeste Dauern.

disponibile con
available
verfügbar



Porta pedonale Stop&Go
Pedestrian door Stop&Go
Schlupftür Stop&Go

COLORI e FINITURE LATO ESTERNO

External colours and finishes / Farben und Ausführungen der Außenseite

Pannelli in Okoumé

Okoumé panels / Paneele von Okoumé



Neutro
Transparent
Durchsichtige



Noce chiaro
Light walnut
Heller Nussbaum



Noce scuro
Dark walnut
Dunkler Nussbaum



Douglas



Rovere chiaro
Light durmast
Heller Eichenholz



Rovere scuro
Dark durmast
Dunkler Eichenholz

Laccatura, verniciatura a campione
Lacquering, painting according to sample
Lackierung nach Münster

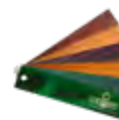

Fresature Verticali

Vertical millings
Senkrechte Fräsungen

DISEGNO LATO ESTERNO

External side drawing / Motiv der Außenseite





Gara

CONFIGURAZIONI

/ Configurations / Ausstattungen

Gara, il sezionale che rappresenta la perfetta sintesi tra design, gusto estetico e un deciso ritorno alla materia. La lavorazione dei pannelli in multistrato marino del legno Okoumè con fresatura orizzontale donano uno stile sobrio, raffinato ed elegante a qualsiasi ambientazione in cui Gara è inserito.

Gara, the sectional which represents the perfect synthesis of design, aesthetic taste and simplicity. The processing of multi-ply Okoumé panels with horizontal millings grant a sober, refined and elegant style to every environment.

Die Perfekte Zusammenfassung zwischen Design und echte Schönheit der Materiale. Die Okoumé Schichholz-Paneele, mit waagerechten Fräsungen, geben einen maßvollen Stil hin, in irgendwelcher Einbausituation.

disponibile con
available
verfügbar



Porta pedonale Stop&Go
Pedestrian door Stop&Go
Schlupftür Stop&Go

COLORI e FINITURE LATO ESTERNO

External colours and finishes / Farben und Ausführungen der Außenseite

Pannelli in Okoumè Okoumè panels / Paneele von Okoumè



Neutro
Transparent
Durchsichtige



Noce chiaro
Light walnut
Heller Nussbaum



Noce scuro
Dark walnut
Dunkler Nussbaum



Douglas



Rovere chiaro
Light durmast
Heller Eichenholz



Rovere scuro
Dark durmast
Dunkler Eichenholz

Laccatura, verniciatura a campione
Lacquering, painting according to sample
Lackierung nach Muster



Fresature Orizzontali

Horizontal millings
Waagerechte Fräsungen

DISEGNO LATO ESTERNO

External side drawing / Motiv der Außenseite





Disegni Speciali

CONFIGURAZIONI

/ Configurations / Ausstattungen

Il modello Disegni Speciali by Breda offre una nuova interpretazione di creatività e stile applicati al portone sezionale grazie all'infinità possibilità di personalizzazione secondo il proprio gusto e la propria fantasia affinché esso possa adattarsi alla perfezione allo stile e alla tipicità della propria abitazione.

The model Disegni Speciali by Breda offers a new creativity and style performance on the sectional doors thanks to the possibility of customising according to the own taste and fantasy, with a perfect final harmony with the house.

Das Modell mit Sonder-Motive bietet eine neue, originelle Tor-Darstellung: eine reiche Fräsungen-Vielfalt, personalisiert nach euerem Geschmack und Fantasie. Dieses Tor richtet sich, nach euerem Stil und Heim.

COLORI e FINITURE LATO ESTERNO

External colours and finishes / Farben und Ausführungen der Außenseite

Pannelli in Okoumè

Okoumè panels / Paneele von Okoumè



Neutro
Transparent
Durchsichtige

Noce chiaro
Light walnut
Heller Nussbaum

Noce scuro
Dark walnut
Dunkler Nussbaum

Douglas

Rovere chiaro
Light durmast
Heller Eichenholz

Rovere scuro
Dark durmast
Dunkler Eichenholz

Laccatura, verniciatura a campione
Lacquering, painting according to sample
Lackierung nach Muster

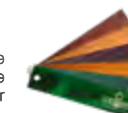

Disegni speciali

Special drawings
Sonder-Motive

DISEGNO LATO ESTERNO

External side drawing / Motiv der Außenseite





Pegaso Line, la linea di sezionali
in legno leggera, tecnologica e moderna.
Portoni che sono già leggenda.

Pegaso Line, the range of sectional made
with light, technologic and modern wood.
Doors which are already a legend!

Pegaso Line, die leichte, moderne
und technologische Holztor-Linie.
Ein Tor, eine Sage.

Tre modelli leggeri per natura,
dove la struttura in alluminio e la
tecnologia applicata reinterpretano
al futuro l'antico fascino di un
materiale nobile come il legno.
Tre versioni pratiche, belle e
funzionali con esclusivi sistemi di
sicurezza e massima possibilità
di personalizzazione per uno stile
ineguagliabile nel segno di Breda.

Three light models, where the
aluminium frame and technology
enrich the old charm of a noble
material as wood is. Three practical,
beautiful and functional versions
with exclusive safety systems
and several personalization
possibilities, with a final inimitable
style, the Breda ones!

Die Leichtigkeit dieses Konzept
steht in der Alu-Struktur und in der
Technologie, die, zusammen, stellen
den antiken und adligen Zauber
des Holzes dar. Drei schönen,
zweckmäßige und praktische
Versionen mit ausgezeichnete
Sicherheitsvorrichtungen und
Personalisierungsmöglichkeiten,
in dem unvergleichbaren Breda-
Style.

Pegaso Line





Pegaso Standard

CONFIGURAZIONI

/ Configurations / Ausstattungen

Pegaso Standard, il must della linea Pegaso dall'elegante gusto estetico che garantisce una insolita e quantomai importante combinazione tra leggerezza strutturale e requisiti di robustezza e di resistenza nel tempo superiori alla norma. La versione standard garantisce inoltre la possibilità di coordinare le finiture dei pannelli di legno Okoumè con il resto dei serramenti della propria abitazione.

Pegaso Standard, the must from Pegaso range with an elegant aesthetic taste, which grants a special combination of structural lightness and at the same time strength and resistance, above the normal. The standard version grants also the best combination between the finishing of the wood Okoumè panels with all the frames from the house.

Pegaso Standard, der „must“ der Pegaso Line. Der elegante, ästhetische Geschmack erlaubt eine wichtige Zusammenstellung zwischen der Leichtigkeit der Struktur und der jahrelangen Haltbarkeit. Die standard Version gibt die Möglichkeit dazu, die Okoumèholz-Paneele mit den Hausfenster und Türe, zu kombinieren.

Struttura interna Pegaso
Internal structure Pegaso
Rahmen innen Pegaso



Telajo in alluminio con isolamento in polistirene e tamponatura del lato interno con lastra in vetroresina bianca.
Aluminium frame with polystyrene insulation and inner cladding with white fibreglass.
Alu-Rahmen mit Dämmung aus Polystyren und Verkleidung der Innenseite durch weißer Glasfaserplatte.

COLORI e FINITURE LATO ESTERNO

External colours and finishes / Farben und Ausführungen der Außenseite

Pannelli di tamponamento in Okoumè

Pannels fillings in Okoumè / Füllungen von Paneele von Okoumè



Neutro
Transparent
Durchsichtige



Noce chiaro
Light walnut
Heller Nussbaum



Noce scuro
Dark walnut
Dunkler Nussbaum



Douglas



Rovere chiaro
Light durmast
Heller Eichenholz

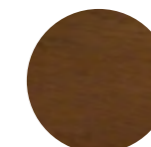

Rovere scuro
Dark durmast
Dunkler Eichenholz

Laccatura, verniciatura a campione
Lacquering, painting according to sample
Lackierung nach Muster

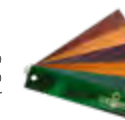

Liscio
Smooth
Glatt



Polis



Civic



Gara

DISEGNO LATO ESTERNO

External side drawing / Motiv der Außenseite



Pegaso Special

CONFIGURAZIONI

/ Configurations / Ausstattungen

La versione Special di Pegaso Line è un inno alla fantasia e alla creatività grazie all'ampia possibilità di personalizzazione dei disegni, delle finiture e delle lavorazioni che lo rendono facilmente adattabile a qualsiasi contesto abitativo.

The version Special from Pegaso Line is a must of fantasy and creativity thanks to the several possibilities of personalisation, with drawings, several finishing and processing which grant a perfect adaptability to all the home contexts.

Die Special Version der Pegaso Line ist das Höchstmaß der Fantasie und Kreativität, dank der Vielfalt der Personalisierungen, durch Zeichnungen, Farbe und Fertigungen. Dieses Tor fügt sich in irgendwelcher Einbausituation ein.

Struttura interna Pegaso Internal structure Pegaso Rahmen innen Pegaso



Telajo in alluminio con isolamento in polistirene e tamponatura del lato interno con lastra in vetroresina bianca.
Aluminium frame with polystyrene insulation and inner cladding with white fibreglass.
Alu-Rahmen mit Dämmung aus Polystyren und Verkleidung der Innenseite durch weißer Glasfaserplatte.

COLORI e FINITURE LATO ESTERNO

External colours and finishes / Farben und Ausführungen der Außenseite

Pannelli di tamponamento in Okoumè

Pannels fillings in Okoumè / Füllungen von Paneele von Okoumè



Neutro
Transparent
Durchsichtige



Noce chiaro
Light walnut
Heller Nussbaum



Noce scuro
Dark walnut
Dunkler Nussbaum



Douglas

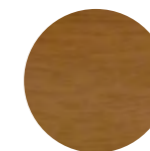

Rovere chiaro
Light oak
Heller Eichenholz



Rovere scuro
Dark oak
Dunkler Eichenholz

Laccatura, verniciatura a campione
Lacquering, painting according to sample
Lackierung nach Muster

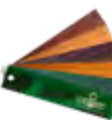

Disegni speciali

Special drawings
Sonder-Motive

DISEGNO LATO ESTERNO

External side drawing / Motiv der Außenseite

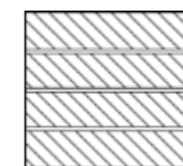

Azalea

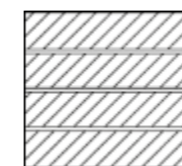

Aralia

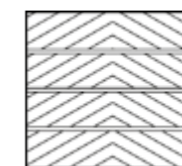

Crocus



Camelia

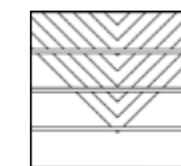

Fresia

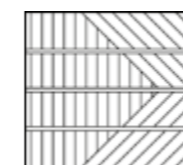

Ortensia

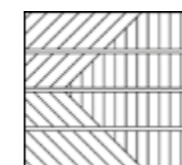

Orchidea

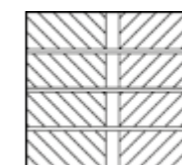

Viola



Loto



Lilla

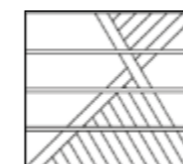

Begonia

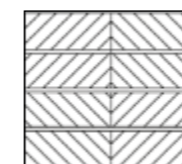

Dalia

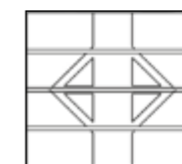

Ninfea

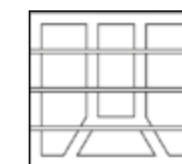

Gerbera



Giglio

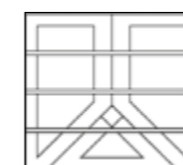

Petunia

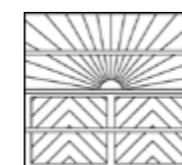

Aster

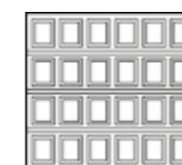

Glicine

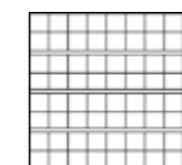

Mimosa

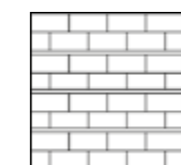

Rosa



Pegaso Doga

CONFIGURAZIONI

/ Configurations / Ausstattungen

Portone sezionale realizzato con speciali profilati in alluminio e applicazione di doghe disponibili nella versione verticale e, di recente, anche orizzontale dallo spessore di 12 mm, per regalare un insieme di armonia strutturale e di forte linearità. Elevati standard tecnologici e di sicurezza fanno di Pegaso Doga la soluzione ideale per qualsiasi abitazione.

A sectional door made with special aluminium profiles and vertical ribs, of late also horizontal, with 12 mm thickness, to grant a final harmonic structural and linear result. The high technologic and safety standards make Pegaso Doga the ideal solution in every house.

Dieses Sektionaltor besteht aus besonderen Alu-Profilen, mit senkrechte oder waagerechte 12mm Dauben, für eine harmonische und lineare Zusammenstellung. Pegaso Doga, dank seiner Sicherheitsvorrichtungen, passt zu jedem Hausstil an.

COLORI e FINITURE LATO ESTERNO

External colours and finishes / Farben und Ausführungen der Außenseite

Telaio e doghe

Frame and aluminium ribs / Alu-Rahmen und Alu-Dauben

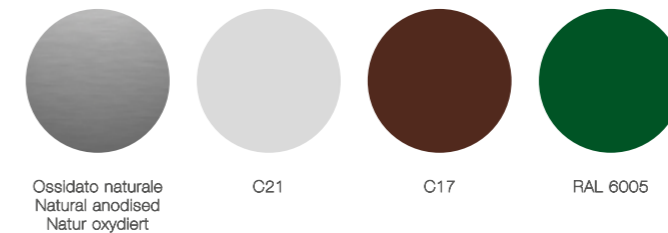

Colori Optional RAL
Optional RAL Colours
RAL Sonder-Farben



Fresature Verticali
Vertical millings
Senkrechte Fräsungen



Fresature Orizzontali
Horizontal millings
Waagerechte Fräsungen

DISEGNO LATO ESTERNO

External side drawing / Motiv der Außenseite





Formiamo i nostri rivenditori e installatori con corsi di specializzazione periodici per trasferire tutta la conoscenza e l'innovazione tecnologica che introduciamo nei nostri prodotti. Fai la scelta migliore: per il tuo portone residenziale, chiedi consiglio al tuo Rivenditore Breda, l'unico esperto in grado di capire le tue esigenze di spazio e i tuoi gusti.

We periodically propose trainings to our Dealers and Installers with specialized courses in order to pass on all our knowledge and technological innovation that we continuously introduce in our products. Take the best decision: Always ask your Breda Dealer for your Residential garage door. He's the only expert able to understand your space needs and your taste.

Wir bilden unsere Händler und Monteure durch periodische Spezial-Kurse aus; dies um die Kenntnisse und technische Entwicklung, die wir in unseren Produkten ständig einführen, zu übertragen. Mach mal die beste wahl: für dein Haustor frag mal bitte deinem Breda Händler. Er kennt genau deinen Geschmack und Bedürfnisse.

Cerca i rivenditori Breda
 Search Breda dealers
 Suche Breda's
 Verkaufsnetz

www.bredasys.com
www.bredasys.com/en
www.bredasys.com/de



Siamo sempre On-line
 We are always On-line
 Wir Sind Immer On-line

Facebook - Instagram- Twitter - YouTube

Showroom Breda

Ogni showroom Breda è casa tua.
 In every Breda Showroom you feel like home.
 In jeder Breda Ausstellung sind sie Zuhause.



Le informazioni riportate hanno valore puramente indicativo e possono in qualsiasi momento essere modificate dalla Breda Sistemi Industriali S.p.A. I colori raffigurati sono puramente indicativi.

Please note that information published on this catalogue are purely indicative and provided as a suggestion. Breda reserves its unappealable right to change it at anytime. Colours here represented are approximate and may differ from the original.

Die hier aufgeführten Informationen dienen nur der Erläuterung und können von der Firma Breda jederzeit geändert werden, wobei diese das unanfechtbare Recht hat, Änderungen vorzunehmen. Die dargestellten Farben dienen nur zu Präsentationszwecken und können vom Original abweichen.

Progetto e concept: Breda Marketing
 Testi: Luca Drigani/Laura Menis
 Stampa: Tipografia Menini

Dicembre 2023

Breda è anche / Breda is also / Breda ist auch:

- ▶ Portoni Residenziali / Residential Doors / Sektionaltore für Wohnbereich
 - ▶ Chiusure industriali / Industrial doors / Industrietore
 - ▶ Le Perle



Li trovi sul nostro sito
Find them in our website
Finden Sie auf unserer Website

www.bredasys.com

